

GR Blue PRO



Impeller with grinder system

DESIGN BY

pininfarina

General characteristics

impeller with grinder system	
motor power	0,74 ÷ 1,5 kW
poles	2
delivery port	GAS 1 1/2"-DN32 horizontal
free passage	-
max flow rate	5.6 l/s
max head	27 m

Electromechanical assembly

Electromechanical assembly in EN-GJL-250 cast iron, for submerged operation, fitted with 2 (two) opposing silicon carbide mechanical seals in oil sump, and V-ring in direct contact with the liquid. Ecological dry motor. Pump body in single casting with motor casing.

Applications

Recommended for unstrained civil wastewaters, including those containing filaments or fibres. This electric pump is intended for both domestic and professional use.

Construction materials

Case	Cast iron EN-GJL 250
Impeller	Cast iron EN-GJL-250
Nuts and bolts	Stainless steel - Class A2-70
Standard gasket	Rubber - NBR
Cutter material	Chromium steel - X102 CrMo17 KU
Cutting disk material	Chromium steel - X102 CrMo17 KU
Shaft	Stainless steel - AISI 420
Paint type	Ecological bicomponent epoxy (medium thickness 80 µm)
Set of standard mechanical seals	Two silicon carbide mechanical seals (2SiC)

Operating limits

Maximum operating temperature	40 °C
PH of treated fluid	6 ÷ 11
Viscosity of treated fluid	1 mm ² /s
Maximum immersion depth	20 m
Density of treated fluid	1 Kg/dm ³
Maximum acoustic pressure	70 dB
max starts per hour	20

Models available in IECEx certified version

Ex nA IIC T3
Ex nA nC IIC T3

GR BluePRO

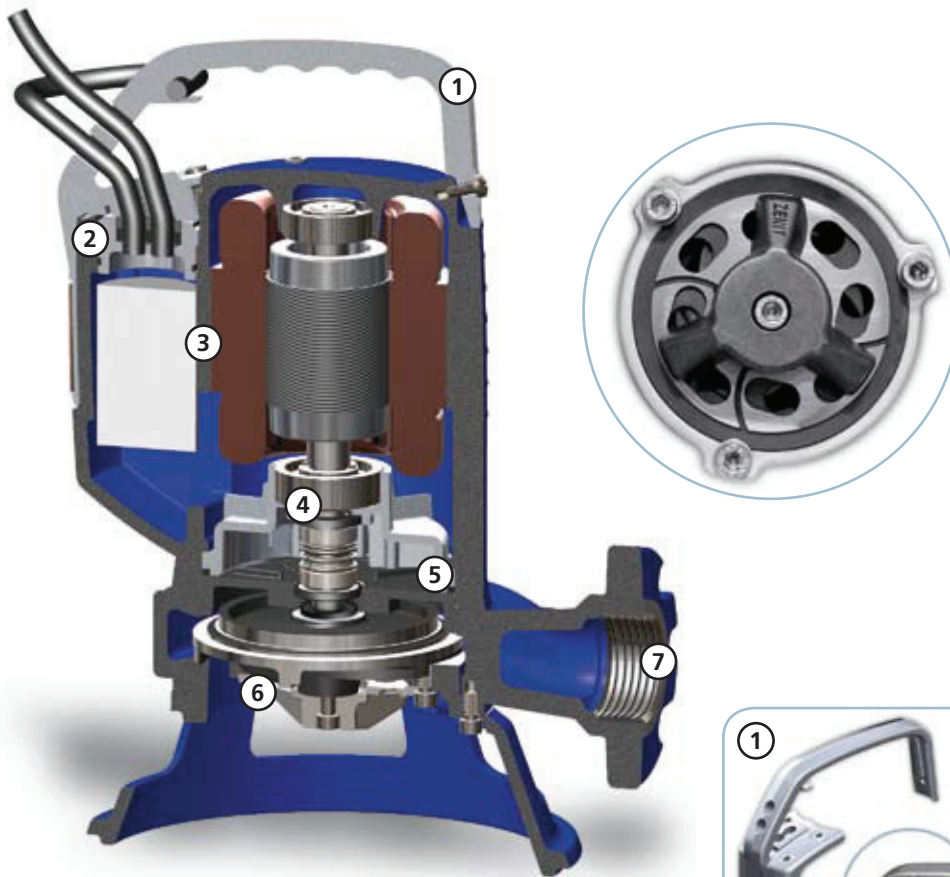

Lifting handle

Ergonomic technopolymer lifting and carrying handle. Clip floatswitch adjustment.



Cable gland System

Innovative cable gland system with twin O-rings to ensure maximum tightness

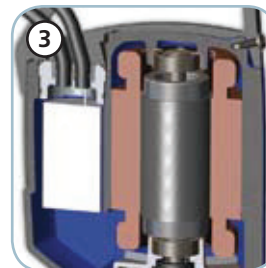

Motor and electrical equipment

Dry motor with thermal protections. Single-phase models with internal capacitor and control cabinet with circuit breaker capacitor and overload protection. Three-phase models with motor protection relay



Mechanical seals

Two silicon carbide mechanical seals (2SiC)

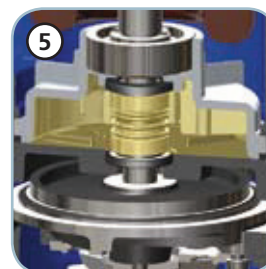

Oil sump

Oil sump which guarantees longer mechanical seal lifetime, and is easily accessible thanks to a patented system to simplify maintenance procedures

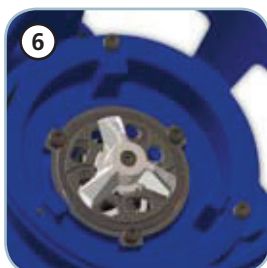

Cutter

Grinder system comprising a revolving cutter and a plate with holes with sharpened edges that fine-chops filaments, preventing fouling of the impeller

Up to 69.000 cuts per minute



Delivery port and foot

Threaded, flanged delivery port for the maximum ease of installation. Cast iron foot.

GR Blue PRO

Models with horizontal GAS 1 1/2" threaded delivery port and DN32 PN6 flange - 2 poles

Performances

	l/s	0	1	2	3	4	5
	l/min	0	60	120	180	240	300
	m ³ /h	0	3.6	7.2	10.8	14.4	18.0
① GR BluePRO 100/2/G40H A1CM(T)/50		18.0	16.4	14.4	11.5	6.9	
② GR BluePRO 150/2/G40H A1CM(T)/50		21.1	19.6	17.9	15.1	10.4	3.0
③ GR BluePRO 200/2/G40H A1CM(T)/50		27.0	25.6	23.6	20.7	16.1	9.3

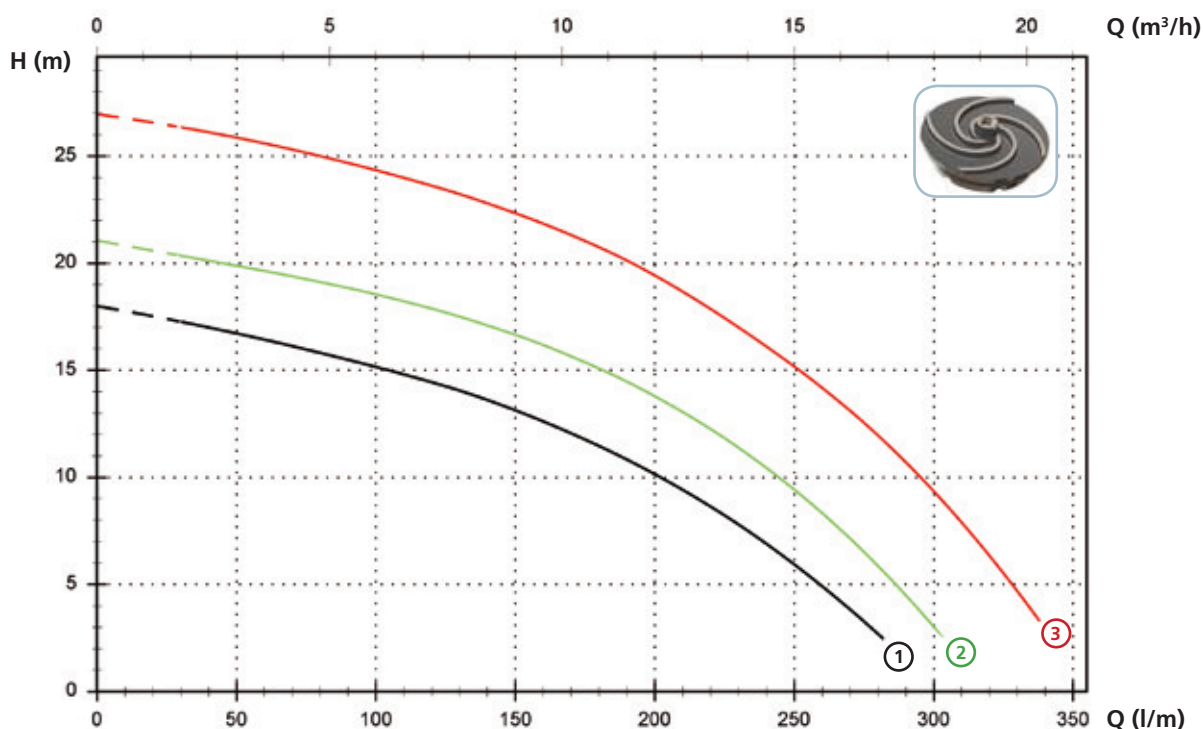

Technical data

	V	Phases	P1 (kW)	P2 (kW)	A	Rpm	Start	Ø	Cable (*)	Free passage
① GR BluePRO 100/2/G40H A1CT/50	230	1	-	0.74	5.5	2900	Dir	G 1 1/2"-DN32 PN6	A	-
② GR BluePRO 150/2/G40H A1CT/50	230	1	-	1.1	7.5	2900	Dir	G 1 1/2"-DN32 PN6	A	-
③ GR BluePRO 200/2/G40H A1CT/50	230	1	-	1.5	10	2900	Dir	G 1 1/2"-DN32 PN6	A	-
① GR BluePRO 100/2/G40H A1CT/50	400	3	-	0.74	2.7	2900	Dir	G 1 1/2"-DN32 PN6	B	-
② GR BluePRO 150/2/G40H A1CT/50	400	3	-	1.1	3.2	2900	Dir	G 1 1/2"-DN32 PN6	B	-
③ GR BluePRO 200/2/G40H A1CT/50	400	3	-	1.5	4.3	2900	Dir	G 1 1/2"-DN32 PN6	B	-

(*) A = H07RN-F 3G1 - 5 m cable length. Optional 10 m cable length
 B = H07RN-F 4G1 - 10 m cable length

Attention: Standard EN 60335-2-41 requires the use of a 10 m cable length in outdoor applications

GR BluePRO

Versions available

(Key to versions on page 16)

	Electrical variants											Cooling				Mechanical seals				
	N A E	T	T C	T C D	T C D T	T C D G T	T C G	T C S T	T C S G T	T S	T R	T R G	N	CC CCE	FT	C G F T	2SIC	SICM	SICAL	2SICAL
GR BluePRO 100/2/G40H A1CM/50					●	●							●				●			
GR BluePRO 100/2/G40H A1CT/50											●	●	●				●			
GR BluePRO 150/2/G40H A1CM/50					●	●							●				●			
GR BluePRO 150/2/G40H A1CT/50											●	●	●				●			
GR BluePRO 200/2/G40H A1CM/50					●	●							●				●			
GR BluePRO 200/2/G40H A1CT/50											●	●	●				●			

Overall dimensions and weights

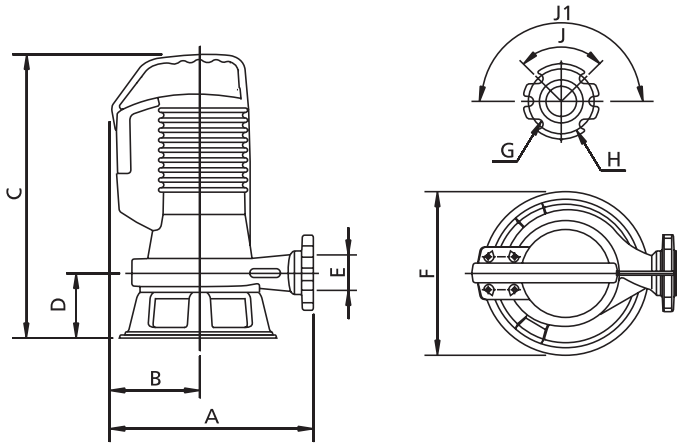

	A	B	C	D	E	F	G	H	J	J1	kg
GR BluePRO 100/2/G40H A1CM(T)/50	270	130	365	95	G 1 1/2"	220	14	90	90°	180°	19
GR BluePRO 150/2/G40H A1CM(T)/50	285	125	410	100	G 1 1/2"	230	14	90	90°	180°	24
GR BluePRO 200/2/G40H A1CM(T)/50	285	125	410	100	G 1 1/2"	230	14	90	90°	180°	25

Measurements in mm

Packaging dimension

	A	B	C
GR BluePRO 100/2/G40H A1CM(T)/50	300	250	400
GR BluePRO 150/2/G40H A1CM(T)/50	300	250	440
GR BluePRO 200/2/G40H A1CM(T)/50	300	250	440

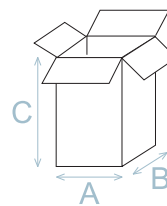

Dimension in mm

No. pieces per pallet

For GR BluePRO models each pallet (EUR 1000X1200 mm) is able to take 32 pieces.

Installations available

